

REVEAL CT-80DR

The Reveal CT-80 product family includes the first Explosives Detection System (EDS) designed for 100% checked baggage inspection. The CT-80DR utilizes Reveal's proprietary Dual Energy, Computed Tomography (CT) architecture. This unique approach to EDS design enables full size checked baggage to be inspected in the smallest possible footprint. The Reveal CT-80DR's detection and low false alarm performance is available for as little as one quarter the cost of traditional certified CT scanners.

AUTOMATED DETECTION

This next-generation system is based on proven CT technology and demonstrated performance of the CT-80 EDS. Dual Energy CT uniquely measures both density and atomic number (Z_{eff}) to provide the highest detection with the lowest possible false alarm rate. Bags are screened automatically for a full spectrum of explosives, with most bags cleared by the system.

THREAT RESOLUTION

By offering the highest image resolution and most advanced threat resolution tools of any EDS system, the Reveal CT-80DR enables operators to quickly and accurately resolve a higher percentage of alarm bags. It also provides an advanced EDS user interface designed to comply with the latest alarm resolution protocols.

DISTRIBUTED ARCHITECTURE

The Reveal CT-80DR is designed to inspect checked baggage, air freight, and parcels in a distributed network of EDS machines. Full multiplexing enables the CT-80DR to send suspect bag images to remote screeners to minimize labor requirements. With a footprint similar to a conventional carry-on baggage X-ray system and the ability to run from single phase power, the compact CT-80DR is ideal for facility protection and other applications where other EDS systems cannot be deployed due to size and cost constraints.



FEATURES

- Dual energy computed tomography
- 226 bags per hour (initial throughput)
- Accommodates full size checked baggage
- Smallest size of any certified EDS
- Low false alarm rate
- Fully multiplexed architecture
- TIP enabled
- FDRS ready
- Runs on single phase, 200 – 240 VAC, 50/60Hz, 20 Amp service (30 Amp with a UPS)
- Floor Loading: no structural changes required for typical airport terminals



REVEAL CT-80DR

PHYSICAL SPECIFICATIONS

DIMENSIONS	TUNNEL SPECIFICATIONS	MAX. BAG SIZE	THROUGHPUT	POWER
L: 244.13 cm (96.11 in) W: 140.08 cm (55.15 in) H: 146 cm (57.5 in)	Diameter: 80 cm (31.5 in) Belt width: 62.3 cm (24.5 in) Belt height: 46.4 cm (18.25 in) Max load: 55 kg (121 lbs)	L: 120 cm (47.2 in) W: 80 cm (31.5 in) H: 63.5 cm (25 in)	226 bags/hr	Single Phase 200-240 VAC, 50/60 Hz, 20 Amp (30 Amp with a UPS)

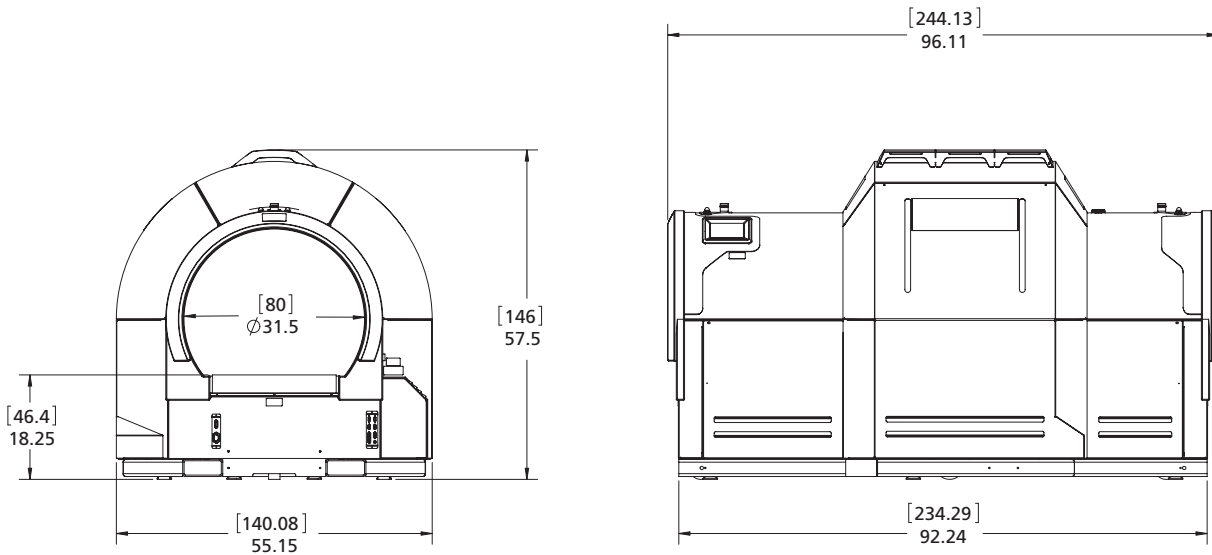

HEALTH AND SAFETY COMPLIANCE

- FAA 14 CFR 108.17 use of X-ray systems
- FAA 14 CFR 108.20 use of explosive detection systems
- FAA 14 CFR 129.26 use of X-ray systems
- CDRH 21 CFR 1020.40 Cabinet X-ray systems
- FCC 47 CFR part 15
- NRTL, UL, CSA approved
- CE mark conforming to CE directives and standards
- Maximum X-ray leakage < 0.1mR/Hr

OPERATING TEMPERATURE

- Without optional A/C unit: 5°C to 32°C (41°F to 90°F)
- With optional A/C unit: 5°C to 40°C (41°F to 104°F)

RELATIVE HUMIDITY

- 10% to 90% non-condensing

IMAGING PERFORMANCE

- X-Ray resolution: 36 AWG tinned copper wire in air
- X-Ray resolution: ASTM F792-01 1.0 mm line pair resolution in both directions
- X-Ray penetration: 24 AWG behind 5/16 inch steel

- X-Ray penetration: Steel 30 mm per ASTM F792-01
- CT pixel resolution: 0.80 mm
- High-res flat panel display
- 1600 x 1200 video resolution

IMAGING FUNCTIONS

- Gray scale, color organic/inorganic/metallic, reverse contrast, multi-level contrast, edge enhancement, interpolated zoom, contrast adjustment, others

AVAILABLE ACCESSORIES

- Gigabit Ethernet communications
- Field Data Reporting System (FDRS)
- Remote threat Resolution viewing Station (RRS)
- Multiplexed Control Console for multiple scanners (MCC)
- Threat Image Protection (TIP)
- Offline TIP image training database
- 1.2 m infeed and outfeed conveyors
- Flat and/or sloped configuration
- Optional tunnel shrouds
- External air conditioning unit
- Operator interlock mat



LCD touch screen Machine Control Interface (MCI)

To see how these solutions can benefit your airport and screening process, please contact us.

World Headquarters:
 Tel.: +1.781.276.8400
sales@revealimaging.com

Europe, Middle East & Africa:
 Tel.: +41.21.905.1721
Bob.Falk@revealimaging.com



Reveal Imaging Technologies, Inc.,
 28 Crosby Drive, Bedford, MA 01730
 Tel: 781.276.8400, Fax: 781.276.8410
www.revealimaging.com

©2010 Reveal Imaging Technologies, Inc. All rights reserved.
 Specifications subject to change without notice.